



# LDM80

## Signal Powered Fiber Optic Converters

### Description

The LDM80 is a small, inexpensive fiber optic transmitter/receiver completely powered by the host RS-232 port. The enclosure for the LDM80 is a conductive shell which greatly reduces RF radiation and susceptibility. The rugged metal enclosure is small enough to mount on the back panel of typical computer equipment saving valuable desk and floor space. A pair of these units allows most RS-232C cable links to be replaced and extended with a duplex fiber optic cable. The normal 50-foot (15m) RS-232 limit may be extended to 2.2 miles (3.5 km). Fiber optic data communications provide complete EMI/RFI rejection, isolation, elimination of ground loops, and reduced error rates. Data security is enhanced by almost nonexistent electromagnetic emissions. The RS-232 connection is through male or female EIA 25-pin connectors. The fiber optic connection is through ST connectors.

The LDM80 is equivalent to a 3-wire, full duplex, RS-232 circuit. Handshake signals are locally connected as in Figure 1. Indicating LEDs come on during a "SPACE" on transmit or receive data. A TD/RD reversing DIP switch is provided for connection to DTE (Data Terminal Equipment) or DCE (Data Communication Equipment) ports.

### Features

- Data Rates to 19.2kbps at 2.2 Miles (3.5km)
- 17dB Optical Link Power Budget
- Powered by RS-232 Host Port Signals
- Full Duplex Asynchronous Operation
- Indicating LEDs
- DCE/DTE Switch
- Designed for FCC Class A Requirements
- Complies with FCC Class A Requirements
- Pinned or Socketed RS-232 Connectors
- CE Compliant

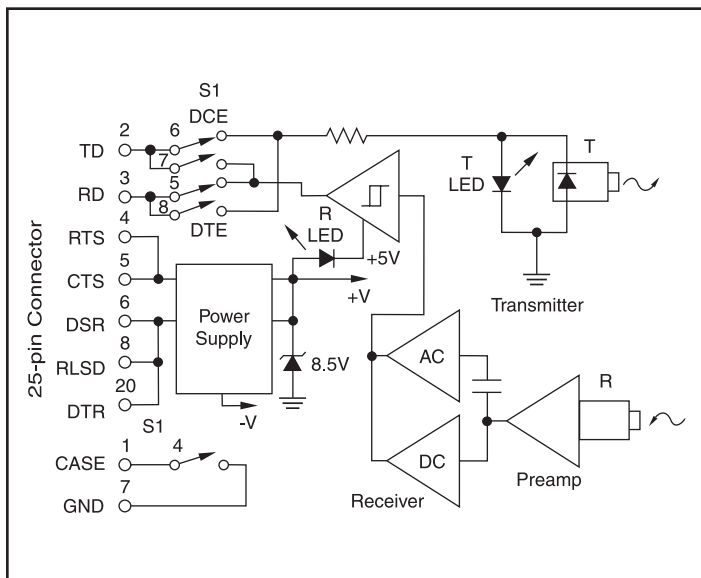



Figure 1: LDM80 Block Diagram

**Specifications** Typical\* at T<sub>A</sub> = +25°C

Model	LDM80	
Bit Rate (bps)	0-19.2k	
Distance Over Bit Rate Range		
Fiber Core Diameter (µm)	Max Cable Length	Loss Budget (dB)
100.0 (glass)	2.2 mi (3.5) (km)	17
50.0 (glass)	1.6 (2.6)	9
62.5 (glass)	1.2 (1.9)	11
85.0 (glass)	2.2 (3.5)	16
200.0 (glass)	2.2 (3.5)	23
1000.0 (plastic)	98 feet 30 (meters)	32
Modes	Asynchronous 2-fiber full duplex, 1-fiber simplex	
Channel Lines <sup>(1)</sup>	TD, RD	
Control Lines <sup>(1)</sup>	RTS, CTS, DTR, DSR, RLSD	
Optical Transmitter	850 nm wavelength	
Output from 1m cable	-26dB typ, -27dB min, -18dB max	
Optical Receiver Power Input for 4µs Pulse Distortion	-44dB min	
Optical Connectors	ST Compatible	
RS-232 Output Voltage with 3kΩ Load	+5V logic 0, -5V logic 1	
DCE/DTE Switch	1	
Diagnostic LEDs	2	
Power		
Port Power and/or DC operation	+5.0 to +8.5VDC, no current limit, 5mA ≥8 .5 VDC, 10mA current limit	
Environmental:		
Operating Temperature Range	-20°C to +70°C	
Storage Temperature Range	-40°C to +85°C	
Relative Humidity	0 to 95% Noncondensing	
Dimensions	3.57" x 2.1" x 0.74" (90.7mm x 53.3mm x 18.8mm)	
Weight	4.2 oz (119g) max	
MTTF <sup>(2)</sup>	≥ 00,000 hrs	

**Ordering Information**

Model	Description
LDM80-P-025	Pinned RS-232 connector, ST fiber optic connector
LDM80-S-025	Socketed RS-232 connector, ST fiber optic connector

Pin Descriptions	Fiber Optic
Pin 1 CASE Ground	
Pin 2 TD [3] Transmit Data	
Pin 3 RD [2] Receive Data	
Pin 4 RTS [7] Request To Send	
Pin 5 CTS [8] Clear To Send	
Pin 6 DSR [6] Data Set Ready	
Pin 7 SIG GND [5] Signal Ground	
Pin 8 RLSD [1] Receive Line Signal Detect	
Pin 20 DTR [4] Data Terminal Ready	

Pin numbers given are for the 25-pin connector with the 9-pin equivalent in [ ].

NOTES:  
 \*Contact factory or your local Dataforth sales office for maximum values.  
 (1) TD = Transmit Data, RD = Receive Data, RTS = Request To Send, CTS = Clear To Send, DTR = Data Terminal Ready, DSR = Data Set Ready, RLSD = Received Line Signal Detect.  
 (2) Ground-benign environmental conditions (no salt atmosphere, <50°C ambient temperature).

**WARNING!** Modern PC ports may not have enough power to power the LDM80 sufficiently for reliable data communications. The user may have to bring in external power through RTS (pin 4), CTS (pin 5), DSR (pin 6), RLSD (pin 8), or DTR (pin 20) and GND (pin 7). The power needs to be at least +5VDC at 5mA for the receive circuits. Also, the Transmit Data port line (pin 2) should be able to provide at least ±5VDC at 5mA minimum.

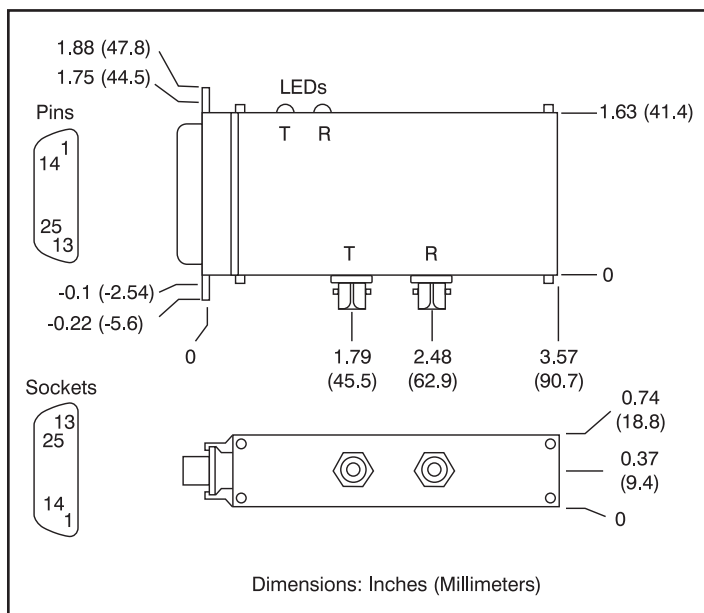

Figure 2: LDM80 Dimensions