

LDM30

General Purpose RS-232 Line Drivers



Description

The LDM30 series of products is designed to allow video display terminals (VDTs) and other RS-232 devices to be connected over distances sufficient to cover any industrial or institutional complex of buildings. These line drivers feature a rugged aluminum enclosure small enough to mount on the back panel of VDT units, saving valuable desk and floor space.

The LDM30 series is designed for full-duplex, asynchronous operation over two, DC-continuity, non-loaded, twisted-wire pairs. Through special high-speed optically-coupled circuits they may communicate at data rates up to 57,600bps. A self-powered model and a host-powered model are available. The self-powered unit uses 12VAC from a wall-mounted transformer while the host-powered unit takes \pm DC power from pins 9 and 10 of the RS-232 connector. The line driver circuits — and, consequently, the host device — are protected from electrical transients due to lightning strikes or operation of heavy industrial equipment.

Each device features a convenient Data-Communication Equipment (DCE) to Data-Terminal Equipment (DTE) switch which reverses pins 2 and 3 of the RS-232 connector. For installation and troubleshooting, each unit has diagnostic Light-Emitting Diodes (LEDs) on the transmit and receive lines.

The RS-232 connector may be ordered as a male or female 25-pin connector. Field connection is made through a modern, solderless, screw-termination assembly.

Features

- DC to 57,600bps
- Optical Isolation
- Surge Protectors
- LED Diagnostic Indicators
- Operation to 3 Miles (5km) at 9600bps,
1 Mile (1.7km) at 19,200bps,
0.5 Miles (0.8km) at 57,600bps
- Four-Wire Full Duplex, Two-Wire Simplex
- Self-Powered or Host-Powered
- Selection of Connectors
- Wide Operating Temperature Range, 0 to +70°C
- CE Compliant

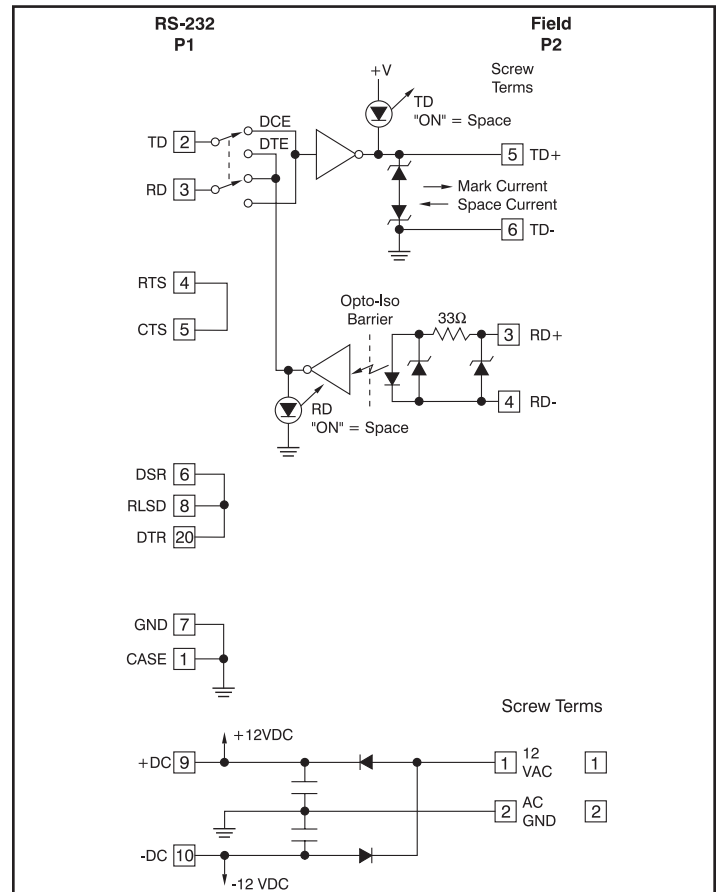

Figure 1: LDM30 Blot Diagram

Specifications Typical* at T_A = +25°C

Model	LDM30
Bit Rate (bps)	0-57.6k
bps vs Distance	57.6k 38.4k 19.2k 9.6k 4.8k 2.4k 1.2k-0
Distance(miles)	0.5 0.75 1.0 3.0 5.0 7.0 12.0
Distance(km)	0.8 1.21 1.6 4.8 8.1 11.3 19.3
Common Mode Isolation	Surge: 500Vp, 1 min. Continuous: 300Vrms
Differential Mode Surge Protection (3 devices)	ANSI/IEEE C37.90.1
Modes	Asynchronous 4-wire full-duplex, 2-wire simplex
Channel Lines ⁽¹⁾	TD, RD
Control Lines ⁽¹⁾	RTS, CTS, DTR, DSR, RLSD
Power	
AC operation ⁽²⁾	12VAC at 92mA
DC operation	±9VDC to ±15VDC, 35mA
Environmental:	
Operating Temperature Range	0°C to +70°C
Storage Temperature Range	-10°C to +85°C
Relative Humidity	0 to 95% Noncondensing
Dimensions	3.6" x 2.1" x 1" (91.4mm x 53.3mm x 25.4mm)
Weight	3.5 oz (100g) max
PT3 and PT3E	11.0 oz (312g) max
MTTF ⁽³⁾	↑ 50,000 hrs

NOTES:

*Contact factory or your local Dataforth sales office for maximum values.

(1) TD = Transmit Data, RD = Receive Data, RTS = Request To Send, CTS = Clear To Send, DTR = Data Terminal Ready, DSR = Data Set Ready, RLSD = Received Line Signal Detect.

(2) 120VAC and 220VAC power transformers are available.

(3) Ground-benign environmental conditions (no salt atmosphere, <50°C ambient temperature).

Ordering Information

Model	Type	Power	Termination
LDM30-P	Male	Host-powered	Screw termination
LDM30-S	Female	Host-powered	Screw termination
LDM30-PT	Male	U.S. transformer	Screw termination
LDM30-ST	Female	U.S. transformer	Screw termination
LDM30-PE	Male	European transformer	Screw termination
LDM30-SE	Female	European transformer	Screw termination

Model	Description
PT3	U.S. style wall mount transformer, 120VAC
PT3E	Euro style wall mount transformer, 220VAC

RS-232 P1 Pin Descriptions			Field P2 Pin Description
Pin 1	CASE	Ground	Screw Terms
Pin 2	TD [3]	Transmit Data	Pin 1 12VAC
Pin 3	RD [2]	Receive Data	Pin 2 AC GND
Pin 4	RTS [7]	Req. To Send	Pin 3 RD+
Pin 5	CTS [8]	Clear To Send	Pin 4 RD-
Pin 6	DSR [6]	Data Set Ready	Pin 5 TD+
Pin 7	GND [5]	Signal Ground	Pin 6 TD-
Pin 8	RLSD [1]	Receive Line Signal Detect	RD+ = Receive Data +
Pin 9	+DC	Positive DC Supply Input	RD- = Receive Data -
Pin 10	-DC	Negative DC Supply Input	TD+ = Transmit Data +
Pin 20	DTR [4]	Data Terminal Ready	TD- = Transmit Data -

Pin numbers given are for the 25-pin connector with the 9-pin equivalent in [].

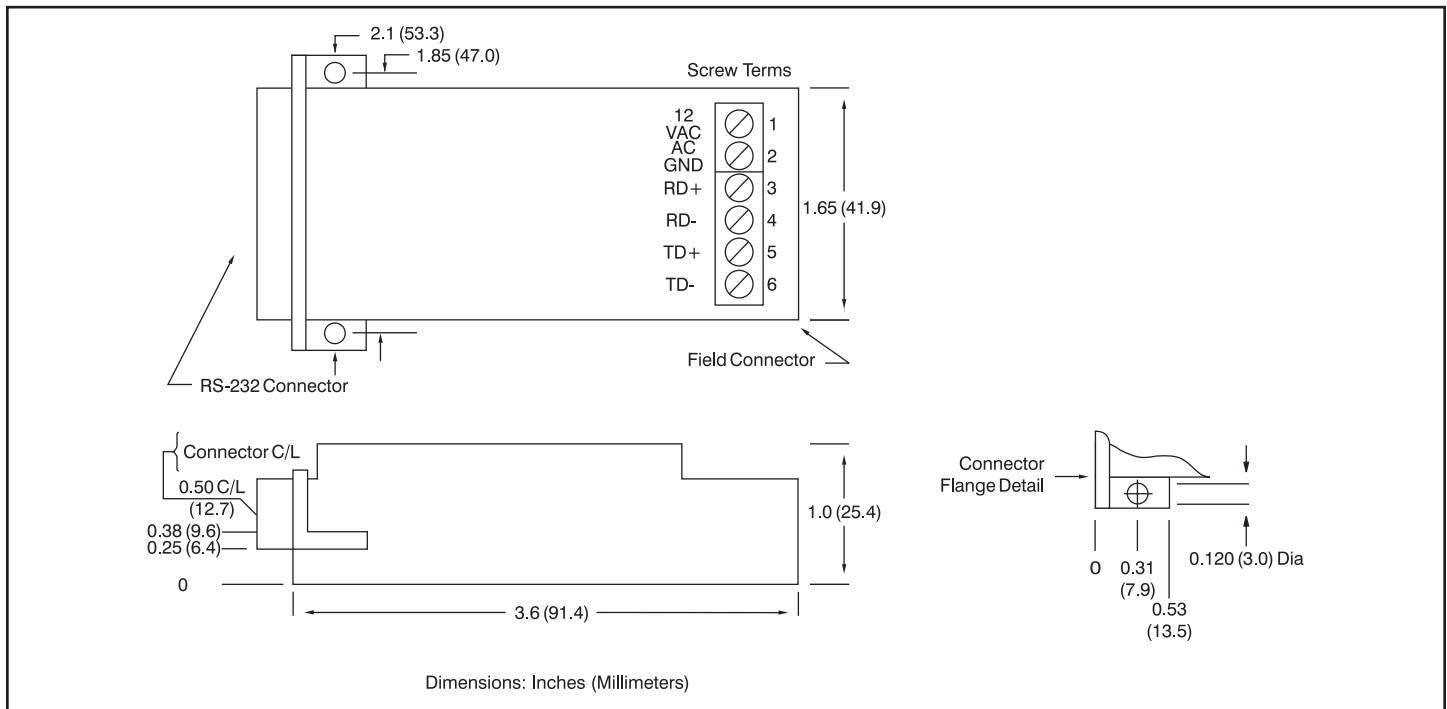

Figure 2: LDM30 Dimensions